

**DISPOSITIVO  
DI APERTURA  
ELETTRONICO**

*ISTRUZIONI  
DI MONTAGGIO*



**ELECTRONIC  
OPENING  
DEVICE**

INSTALLATION  
INSTRUCTIONS

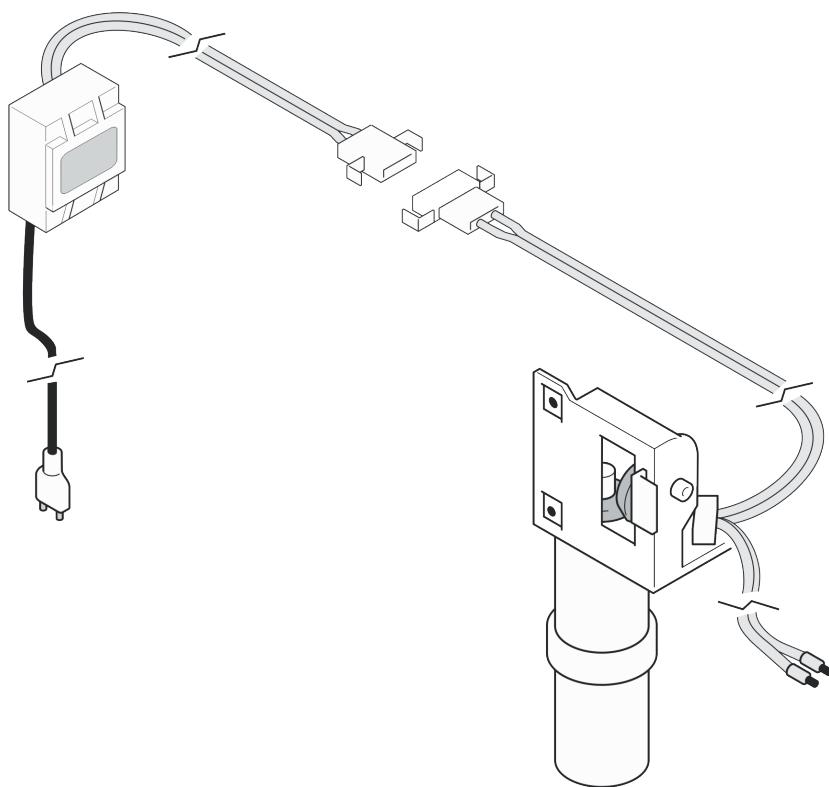



**NOTA!**

*I disegni e qualsiasi altro documento consegnato insieme alla porta, sono di proprietà della DI.BI. che se ne riserva tutti i diritti e ricorda che non possono essere messi a disposizione di terzi senza la sua approvazione scritta.*

*E' quindi rigorosamente vietata qualsiasi riproduzione anche parziale del testo o delle illustrazioni.*

*Grazie per aver scelto DI.BI.*



**ATTENTION!**

The illustrations and any other document that is delivered with the door are the property of DI.BI., which reserves all rights and reminds the user that these documents cannot be distributed to third parties without written approval.

Any reproduction, even partial, of the texts and illustrations is therefore strictly prohibited.

Thank you for choosing DI.BI.

**INDICE**
**INDEX**

<b>TITOLO</b>	<b>CAPITOLO CHAPTER</b>	<b>PAGINA PAGE</b>	<b>TITLE</b>
<i>CONTENUTO SCATOLA</i>		<b>4</b>	BOX CONTENT
<i>OPERAZIONI PRELIMINARI</i>	<b>1</b>	<b>5</b>	PRELIMINARY OPERATIONS
<i>CONTROLLI</i>	<b>2</b>	<b>5</b>	CHECKS
<i>CONTENUTO SCATOLA</i>	<b>3</b>	<b>5</b>	BOX CONTENT
<i>ATTREZZI</i>	<b>4</b>	<b>6</b>	TOOLS
<i>MONTAGGIO DISPOSITIVO DI APERTURA ELETTRONICO</i>	<b>5</b>	<b>7</b>	ELECTRONIC OPENING DEVICE INSTALLATION
<i>TABELLA REVISIONI DEL MANUALE</i>	<b>6</b>	<b>15</b>	CHART OF THE INSTRUCTION MANUAL REVISIONS

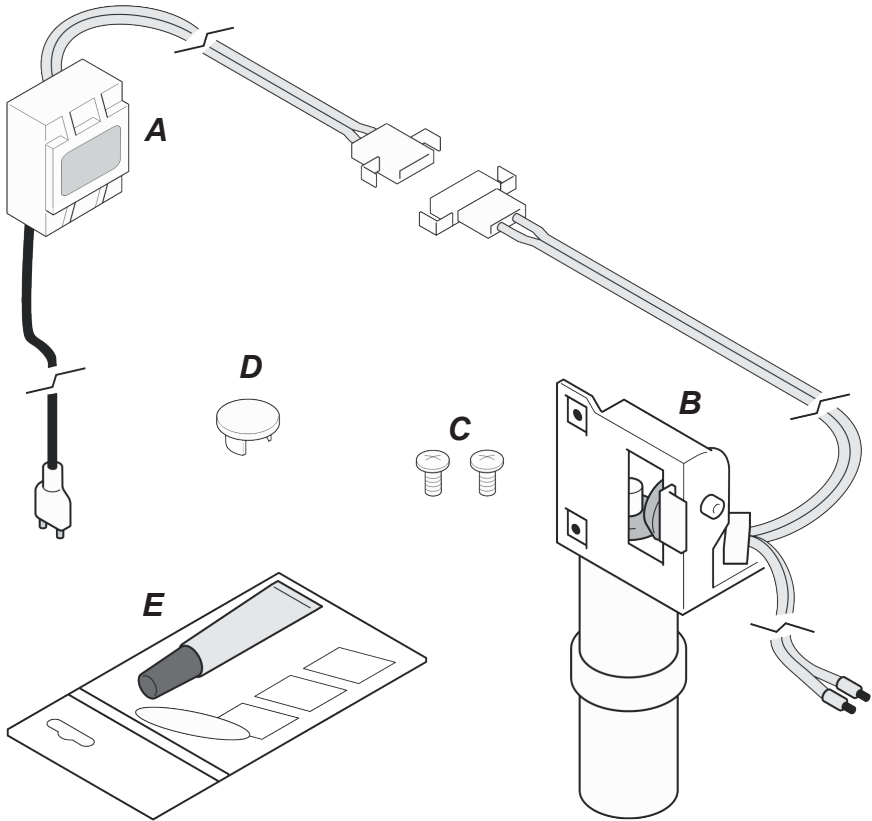

<b>CONTENUTO SCATOLA</b>	<b>POSIZIONE POSITION</b>	<b>QUANTITA' QUANTITY</b>	<b>BOX CONTENT</b>
<i>TRASFORMATORE 220V-12V</i>	<b>A</b>	<b>1</b>	220V-12V TRANSFORMER
<i>DISPOSITIVO DI APERTURA ELETTRONICO</i>	<b>B</b>	<b>1</b>	ELECTRONIC OPENING DEVICE
<i>VITI DI FISSAGGIO DEL DISPOSITIVO</i>	<b>C</b>	<b>2</b>	DEVICE INSTALLATION SCREWS
<i>TAPPO DI CHIUSURA INGRESSO LIMITATORE</i>	<b>D</b>	<b>1</b>	OPENING LIMIT HOLE CLOSURE CAP
<i>COLLA</i>	<b>E</b>	<b>1</b>	GLUE

## CAPITOLO 1 OPERAZIONI PRELIMINARI

Al ricevimento della Scatola del Dispositivo di Apertura Elettronico comportarsi come descritto sulla **GUIDA AL MONTAGGIO PORTA**, Capitolo 1 "PREMESSA", sottocapitolo 1.1.

## CAPITOLO 2 CONTROLLI

Controllare che il CODICE corrisponda all'ordine.

## CAPITOLO 3 CONTENUTO SCATOLA

Aprire la Scatola del Dispositivo di Apertura Elettronico e controllare che il contenuto corrisponda alla Distinta o al foglio all'interno della scatola.

Se corrisponde procedere al montaggio come descritto dal CAPITOLO 4 in poi.

Se non corrisponde, informare il Costruttore come descritto sulla **GUIDA AL MONTAGGIO PORTA**, CAPITOLO 1, sottocapitolo 1.1.

## CHAPTER 1 PRELIMINARY OPERATIONS

When you receive the box of the Electronic Opening Device, follow the instructions in the **INSTALLATION INSTRUCTIONS FOR THE DOOR**, Chapter 1 "INTRODUCTION", item 1.1.

## CHAPTER 2 CHECKS

Check that the CODE matches the order.

## CHAPTER 3 BOX CONTENT

Open the Electronic Opening Device box and check that the content matches the itemized packing list.

If it does match, proceed with the installation as instructed in from CHAPTER 4 on.

If it does not match, contact the Manufacturer as instructed in the **INSTALLATION INSTRUCTIONS FOR THE DOOR**, Chapter 1, item 1.1.

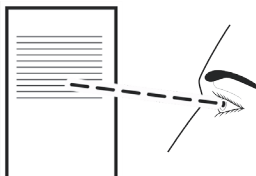
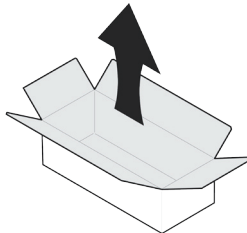
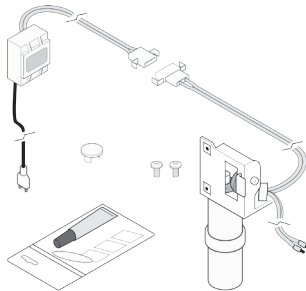
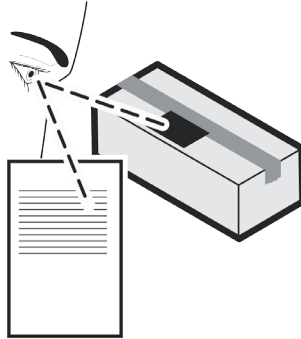

## CAPITOLO 4 ATTREZZI

*In questo Kit non ci sono  
attrezzi in dotazione.  
Utilizzare gli attrezzi citati  
nella Guida al Montaggio Porta  
o Kit Maniglia.*



**NOTA 1!**  
*Normalmente il Dispositivo  
di Apertura Elettronico  
(quando richiesto)  
è montato nel Telaio;  
solo raramente è dato  
in KIT a parte.*

*Ma, siccome il montaggio del  
KIT a parte è più complicato,  
qui di seguito descriviamo  
come montarlo.  
Nel caso il Kit sia già montato  
NON ESEGUIRE LE OPERA-  
ZIONI NON NECESSARIE.*



**NOTA 2!**  
*Nell'aprire la Scatola,  
controllare che il verso del  
Dispositivo sia corretto.*

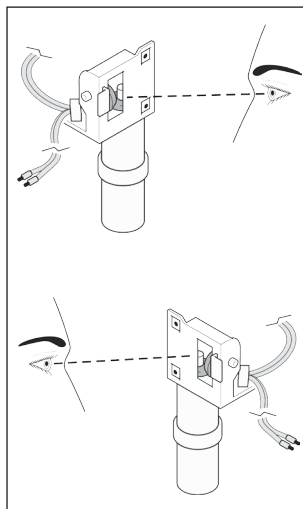

## CHAPTER 4 TOOLS

There are no tools supplied  
in this Kit.  
Use the tools cited in the Instal-  
lation Instructions for The Door  
or the Handle Accessories Kit.



**ATTENTION 1!**  
Normally the Electronic Open-  
ing Device (when requested)  
is installed in the Frame;  
only rarely is it supplied  
separately in a KIT.

However, since the instal-  
lation of the separate KIT is  
more complex, the installa-  
tion instructions for the Kit  
follow.  
In case the Kit has already  
been installed **DO NOT  
PERFORM THE OPERATIONS  
THAT ARE UNNECESSARY.**



**ATTENTION 2!**  
Check that the Device's  
correct side is up when  
opening the Box.

## CAPITOLO 5 MONTAGGIO DEL DISPOSITIVO DI APERTURA ELETTRONICO

5.1  
Consultare la GUIDA AL MONTAGGIO PORTA per **smontare** il Telaio o almeno il lato serratura (Capitolo 5).

5.2  
Con un cacciavite a stella, togliere il Piastrino Regolascrocco.

5.3  
Con una Chiave a Brugola da 5 e una Chiave Fissa da 13, togliere l'asta del Limitatore di Apertura.

5.4  
Togliere la boccia di guida del Limitatore di Apertura.

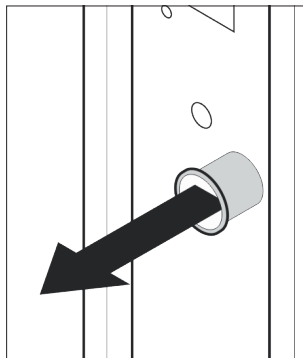
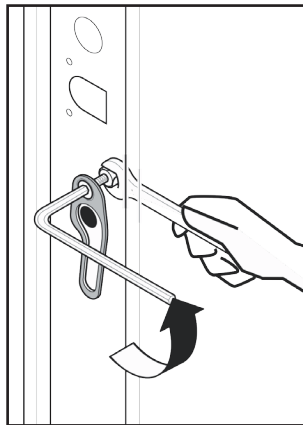
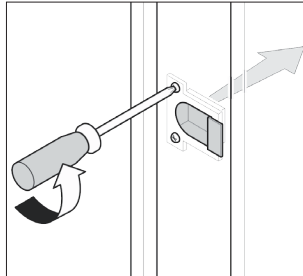

## CHAPTER 5 INSTALLING THE ELECTRONIC OPENING DEVICE

5.1  
Consult the INSTALLATION INSTRUCTIONS FOR THE DOOR to **disassemble** the Frame or the lock area (Chapter 5).

5.2  
Remove the Spring Latch Adjustment plate with a Phillips Head screwdriver.

5.3  
Remove the Opening Limit bar with a 5" Allen Wrench and a 13" Wrench.

5.4  
Remove the hinge bush guide from the Opening Limit.

5.5

*In base alla posizione della presa di corrente ed alla posizione del Pulsante, predisporre un passaggio cavi (a carico dell'elettricista).*

5.5

Make certain that the electrician traces the proper cable paths depending upon the position of the electricity plug and on the position of the Button (the electrician is responsible for this).

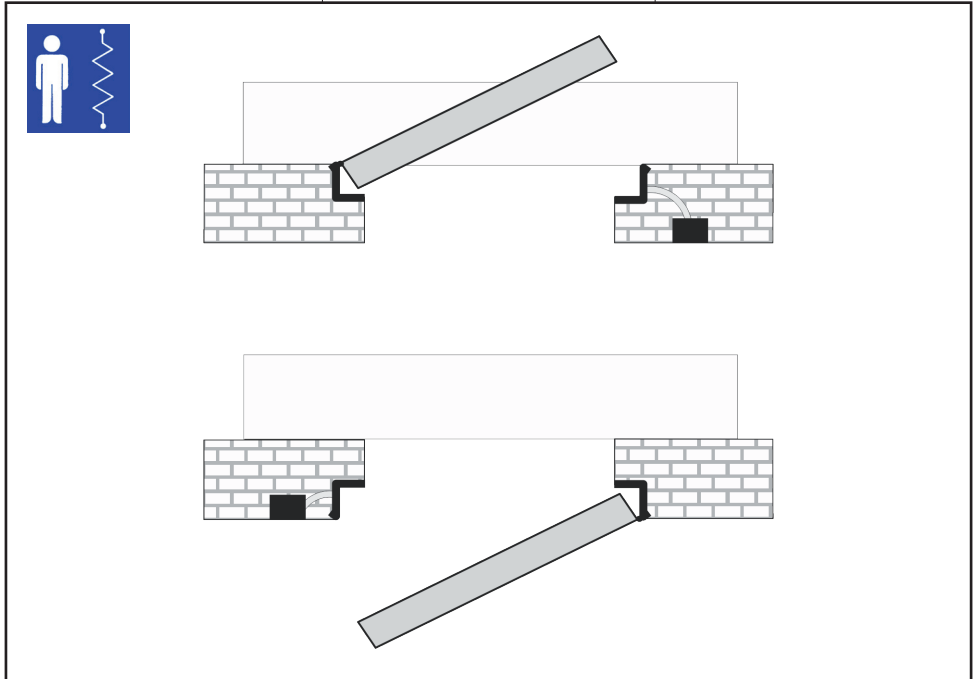

5.6

*Montare il Dispositivo Elettronico (B) al Telaio e fissarlo senza serrare le 2 viti.*

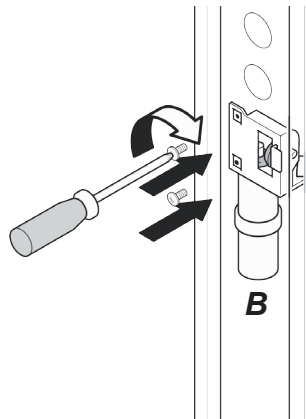

5.6

Install the Electronic Device (B) to the Frame and secure it without tightening the 2 screws.



5.7  
 Incollare il Trasformatore (A)  
 all'interno del Telaio a 10÷15  
 Centimetri sotto il foro  
 del cavallotto Controtelaio.

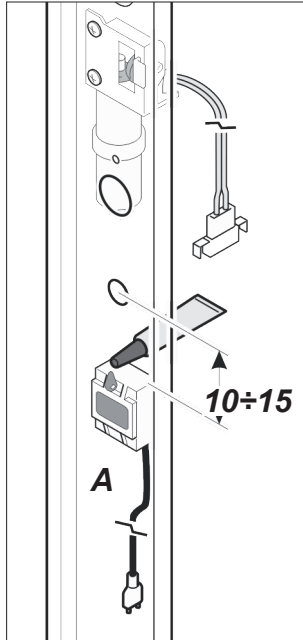

5.7  
 Glue the Transformer (A) to the  
 inside of the Frame at 10÷15  
 centimetres under the hole of  
 the u-bolt Subframe.

5.8  
**ATTENZIONE**  
**RISCHIO DI ROTTURA DEL**  
**DISPOSITIVO A CAUSA**  
**DELL'INVERSIONE DEL**  
**SENSO DI ROTAZIONE!**  
 La ruota del Dispositivo con  
 asse orizzontale, **DEVE RUO-**  
**TARE sempre verso il basso.**  
 (Vedere figura a lato).

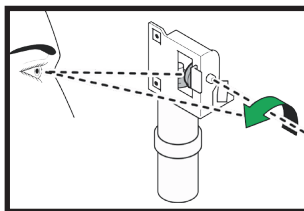

5.8  
**WARNING!**  
**THE DEVICE COULD BE**  
**DAMAGED A CAUSE OF THE**  
**REVERSAL OF ROTATION!**  
 The device wheel turns on a  
 horizontal axis, and it **MUST**  
**ALWAYS ROTATE** downwards.  
 (See figure beside).



**Questa operazione deve es-**  
**essere eseguita da un Elettric-**  
**ista specializzato e abilitato.**  
 Se per qualsiasi motivo si  
 sceglie di togliere i connettori  
 ad innesto e si vuole collegare  
 i cavi con altro sistema, fare  
 attenzione a non invertire i cavi  
 collegandoli sempre corrispon-  
 denti allo stesso colore.

5.9  
 Inserire i 2 Connettori.

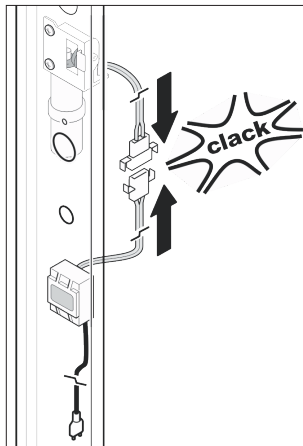

**The procedure must be done**  
**by a trained and qualified**  
**electrician.**  
 If, for any reason, you need  
 to remove the plugs and you  
 want to connect the cables  
 with another system, please be  
 careful not to reverse them, and  
 connect always them with the  
 corresponding colour.

5.9  
 Insert the 2 Connectors.

**5.10**

**ATTENZIONE  
PERICOLO DI SCOSSA  
ELETTRICA!**

*I collegamenti elettrici  
devono essere eseguiti  
da un Elettricista  
Specializzato e abilitato con  
l'impianto di rete elettrico  
su "0" "OFF".*

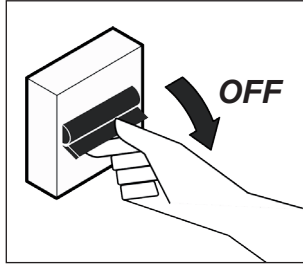

**5.10**

**CAUTION!  
DANGER OF ELECTRIC  
SHOCK!**

The electric connection with electrical system network on "0" or "OFF" must be done by a trained and qualified electrician.

**5.11**

*Far uscire il Cavo del Pulsante  
per apertura e collegarlo  
secondo necessità.*

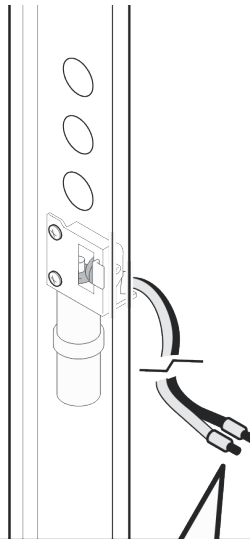

**5.11**

The Opening Button cable should exit in order to be connected as necessary.



**5.12**

**AVVERTENZA!**

*Su questi cavi non deve  
arrivare corrente.*

*Devono essere collegati solo  
al Pulsante con comando  
normalmente aperto.*

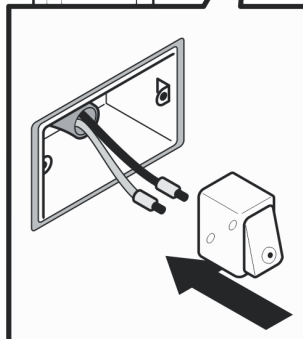

**5.12**

**WARNING!**

Power should not be supplied to these cables.

They should be connected only to the Button with the switch normally open.



**5.13**  
**ATTENZIONE**  
**PERICOLO DI ROTTURA**  
**DEI CAVI ELETTRICI CON**  
**CONSEQUENTE PERICOLO**  
**DI SCHOCK ELETTRICO!**  
*Posizionare i cavi con*  
*connettori come da figura.*

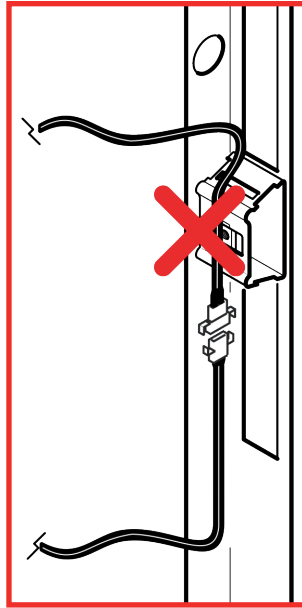

**5.13**  
**CAUTION!**  
**DANGER OF BREAKING**  
**OF ELECTRIC CABLES AND**  
**CONSEQUENT DANGER**  
**OF ELECTRIC SHOCK!**  
*Get in position the cables*  
*with connectors as shown*  
*in figure.*

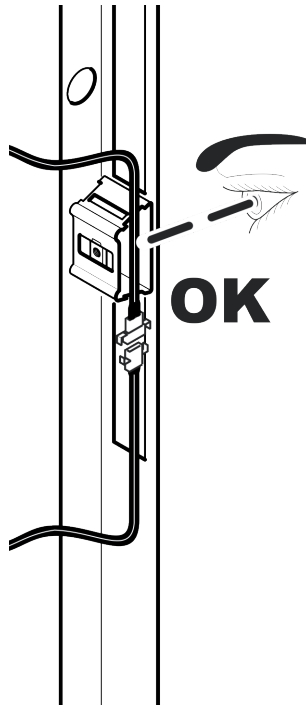

5.14

Assicurandosi di non pizzicare i cavi e consultando la guida **MONTAGGIO PORTA** (Capitolo 5), accostare ed avvitare il Telaio.

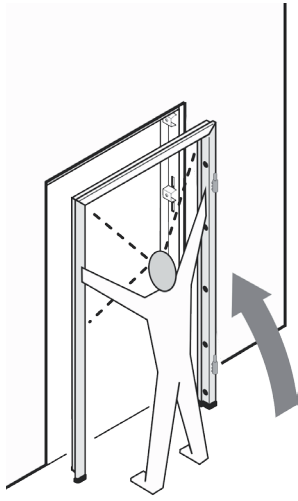

5.14

Accost and tighten the screws on the Frame, making sure not to pinch the cables and all the while consulting the **DOOR INSTALLATION** guide (Chapter 5).



5.15

Far uscire il cavo di Alimentazione e **collegarlo alla rete** o **inserire la spina secondo necessità.**

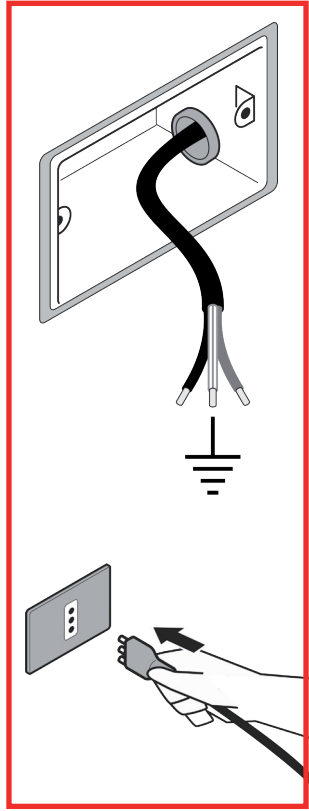

5.15

The power cable should exit in order to be **connected to the network** or to be **inserted into the plug**, depending on the situation.

5.16  
 Posizionare su "1" "ON"  
 l'interruttore di rete.

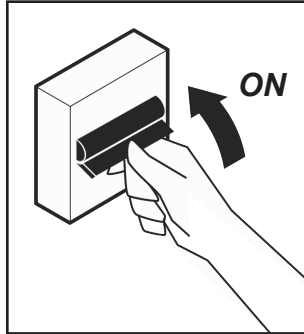

5.16  
 Set to "1" to "ON" the power switch

5.17  
 Sempre consultando  
 la guida **MONTAGGIO PORTA**,  
 regolare il Telaio (Capitolo 8) -  
 ed una volta regolato - serrarlo  
 in modo definitivo.

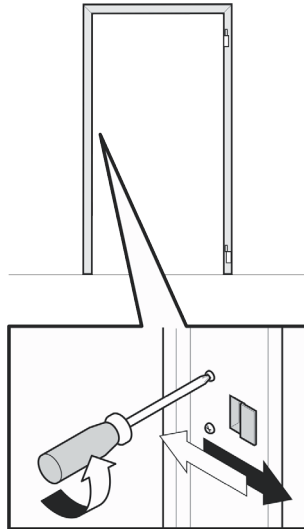

5.17  
 Adjust the Frame (Chapter 8)  
 by consulting the **DOOR IN-  
 STALLATION** guide.  
 Once it has been adjusted,  
 secure it well.

5.18  
 Comportarsi come descritto  
 nella guida **MONTAGGIO  
 PORTA** (Capitolo 8) e regolare  
 la posizione del Dispositivo  
 di Apertura (Regolascrocco);  
 una volta regolato serrarlo  
 in modo definitivo.

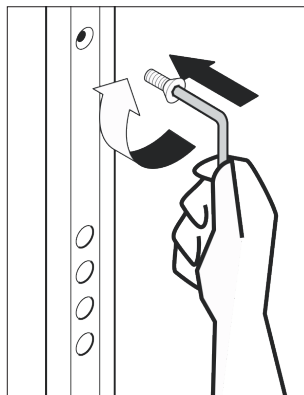

5.18  
 Follow the instructions in the  
**DOOR INSTALLATION** guide  
 (Chapter 8) and adjust the  
 position of the Opening Device  
 (Spring Latch Adjustment);  
 once it has been adjusted,  
 secure it well.

**5.19**

*Inserire il Tappo (D) sul foro del Limitatore di Apertura.*

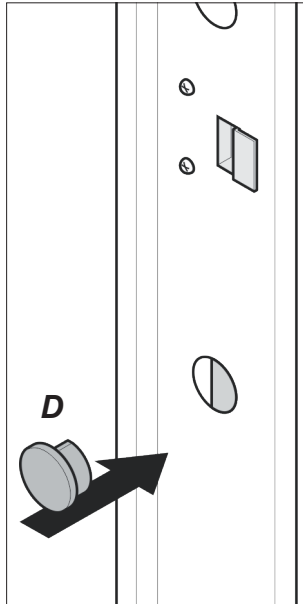

**5.19**

Insert the Cap (D) on the Opening Limit hole.

**5.20**

*Il MONTAGGIO DEL DISPOSITIVO DI APERTURA ELETTRONICO, è terminato.*

**5.20**

The ELECTRONIC OPENING DEVICE INSTALLATION is now complete.

**PARTE 6**  
**TABELLA REVISIONI**  
**DEL MANUALE**

<i>Descrizione</i>	<i>N° Revisione</i>	<i>Data</i>
<i>Edizione 1</i> <i>Emissione</i>	<i>0</i>	<i>Aprile</i> <i>2004</i>
<i>Revisione</i>	<i>1</i>	<i>Novembre</i> <i>2004</i>
<i>Revisione</i>	<i>2</i>	<i>Marzo</i> <i>2017</i>

**PARTE 6**  
**CHART OF THE**  
**INSTRUCTION**  
**MANUAL REVISIONS**

<i>Description</i>	<i>No. Revision</i>	<i>Date</i>
<i>Edition 1</i> <i>Issue</i>	<i>0</i>	<i>April</i> <i>2004</i>
<i>Revision</i>	<i>1</i>	<i>November</i> <i>2004</i>
<i>Revision</i>	<i>2</i>	<i>March</i> <i>2017</i>



**DI.BI. PORTE BLINDATE S.R.L.**

*SEDE LEGALE E AMMINISTRATIVA/ADMINISTRATION AND REGISTERED OFFICES:*

*VIA EINAUDI, 2 (ZONA INDUSTRIALE/INDUSTRIAL AREA)*

*STABILIMENTO/FACTORY: VIA TONIOLO, 13/A (ZONA INDUSTRIALE) - 61032 FANO (PU) - ITALIA/ITALY*

*TEL. +39.0721.81.91 R.A.*

*FAX +39.0721.85.54.60 - FAX +39.0721.854038 (UFFICIO TECNICO/TECHNICAL OFFICE)*

*INTERNET: [www.dibiportebblindate.it](http://www.dibiportebblindate.it) - E-MAIL: [info@dibiportebblindate.it](mailto:info@dibiportebblindate.it) - E-MAIL: [info@dibigroup.com](mailto:info@dibigroup.com)*